



WARN Industrial Winch

Model	Part Number	Motor Type
Series 20XL Hydraulic Winch Manual Clutch	77570	Hydraulic 7.9 ci (130cc)



The Warn Series XL product line combines durable cast iron construction, high efficiency hydraulic motor, and a robust 2X rated load braking system with a permanently lubricated and hardened 2-stage planetary gear train for superior intermittent-duty performance for loads up to 30,000 lbs. Winches are also available with manual or air clutches and 2 drum widths. A roller tension plate is standard along with bi-directional operation and a variety of mounting options to fit a variety of applications.

Warn Series XL winches are not suitable for hoisting applications or movement of persons.

Accessories

Description:	Part Number
Fairlead SRS-XL-LONG	77869
Wire Rope Assembly 9/16"x245' EIPS	77452
Snatch Block XL-60K LB	80858

Engineering Data

Rated Pulling Force:	20000	lbf	9072	kgf
Drum Barrel Diameter:	5.75	in	146	mm
Drum Flange Diameter:	12.25	in	311	mm
Distance Between Flanges:	14	in	356	mm
Recommended Maximum Wire Rope Diameter:	9/16	in	14.3	mm
Recommended Minimum Wire Rope Breaking Strength:	33600	lbf	15241	kgf
Approximate Shipping Weight:	322	lb	146	kg
Duty Cycle (intermittent per SAE J706 section 6.2):	2760	ft	841.2	m
Mounting Bolt Torque:	159	ft*lbf	216	N*m
Maximum Layers of Wire Rope:	5			
Gear Reduction:	28.5:1			
Brake Type:	Spring Applied Disk			
Contact / Remote Type:	N/A			

Drum Rotation

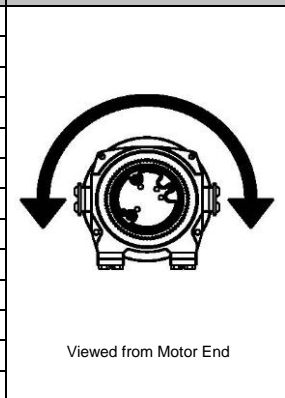

Standards Compliance

- SAE J706
- CE Machinery Directive 98/37/EC and 2006/42/EC

Performance By Layer- 9/16" (14.3 mm) dia. rope

Drum Layer	Line Load *			Line Speed 15 GPM		Line Speed 20 GPM		Drum Capacity	
	lbf	kgf	kN	ft/min	m/min	ft/min	m/min	ft	m
1	20000	9072	89.0	22.8	6.9	28.5	8.7	36	11.0
2	16975	7700	75.5	26.9	8.2	33.5	10.2	79	24.1
3	14745	6688	65.6	31.0	9.4	38.6	11.8	129	39.3
4	13032	5911	58.0	35.0	10.7	43.7	13.3	185	56.4
5	11676	5296	51.9	39.1	11.9	48.8	14.9	248	75.6

* Never exceed the Rated Pulling Force. Installation of a Rated Capacity Limiter is recommended.

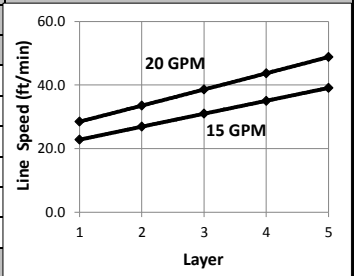

First Layer Performance

Line Load		Pressure Drop at 15 GPM		Pressure Drop at 20 GPM		Duty Cycle
lbf	kgf	psi	BAR	psi	BAR	min/10min
0	0	870	60.0	1055	72.7	N/A
5000	2268	1256	86.6	1500	103.4	N/A
10000	4536	1855	127.9	2070	142.7	N/A
15000	6804	2470	170.3	2630	181.3	N/A
20000	9072	2985	205.8	3000	206.8	N/A

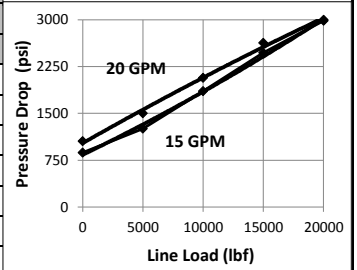

WARN INDUSTRIES, INC
Industrial Products

Customer Service (North America): 1.800.543.9276
Customer Service (International): 1.503.722.3008
FAX: 1.503.722.3000 www.warn.com

12900 S.E. Capps Road,
Clackamas, OR USA 97015



WARN Industrial Winch

Model	Part Number	Motor Type
Series 20XL Hydraulic Winch Manual Clutch	77570	Hydraulic 7.9 ci (130cc)

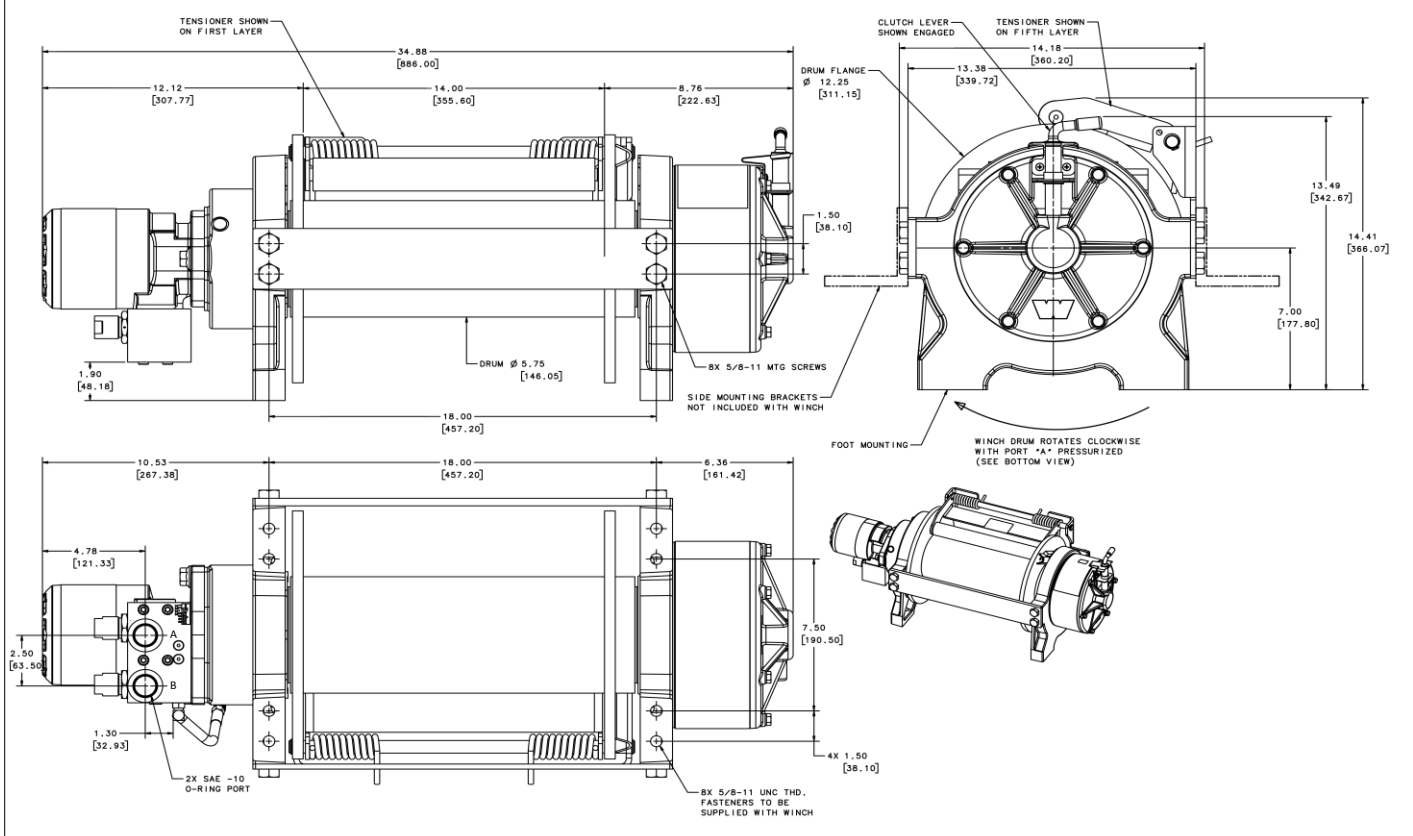

Motor / Contactor may be rotated in 90 degree increments. Clutch housing may be rotated in 60 degree increments.

Units are given in inches [millimeters], unless otherwise specified

Recommended Mounting- Always Observe Correct Drum Rotation			Hydraulic System Specifications	
Pull from bottom of winch Feet down	Pull from bottom of winch Feet forward	Pull from top of winch Feet forward	Maximum System Pressure:	3000 psi 207 BAR
			Maximum Motor Pressure Drop:	3000 psi 207 BAR
			Maximum Rated Input Flow:	20 GPM 76 LPM
			Control Valve Type:	3-position, 4-way, open center, spring return (motor spool)
Control Valve Schematic				
Pull from top of winch Feet down without angle brace	Pull from top of winch Feet down with angle brace	Pull from top of winch Angle Braces Only		
			Note: Drum rotates clockwise with Port A pressurized when viewed from gearbox end.	

WARN INDUSTRIES, INC
Industrial Products

Customer Service (North America): 1.800.543.9276
Customer Service (International): 1.503.722.3008
FAX: 1.503.722.3000 www.warn.com

12900 S.E. Capps Road,
Clackamas, OR USA 97015